

FREE RESIDENT GUIDE



*Buffalo,
Trempealeau
& Pepin
Counties*

WISCONSIN

*What's Inside:
Businesses • Directory • History
Events and more*

COWSMO® COMPOST

Composted Cow Manure meets organic standards, and improves soil structure. Great for landscaping, gardens & mulching.

Potting Soil

Organic, compost based, sustainable



Cowsmo Compost

2 miles North of Waumandee on County Rd. U

608-626-2571

Email: jrosenow@mwt.net

www.cowsmocompost.com

OPEN 7 DAYS A WEEK 8AM - 5PM

Both products available in bulk, 20 lb. & 50 lb. bags and totes. Call for prices and delivery information.



BIZ BARCODE

The White Pig Tavern



• Daily Drink Specials •
• Happy Hour Daily •

Open at 8 a.m. Seven Days A Week!

134 W. Main St. • Mondovi, WI • 715-926-4766

Table of Contents

2-3	Local Area Events
4-5	Residential Services
6	Buffalo County History
7	Buffalo County Communities Alma Buffalo City Fountain City Mondovi
8	Trempealeau County History
9-10	Trempealeau County Communities Arcadia Blair Dodge Galesville Osseo Whitehall
12	Pepin County History
13	Pepin County Communities Durand Pepin Stockholm
14	Local Area Attractions
15	Parks & Recreation
16-17	DNR License Centers
18	Wisconsin Hunting Seasons
19	Wisconsin Trapping Seasons
21	Wisconsin Fishing Seasons
27-29	Bicycle Trails
32-34	Snowmobile Trails

List of Advertisers:

Alma Hotel, Bar & Restaurant • Asher Realty Group • Marge Nicolai • Corral Bar & Riverside Grill
Cowsmo Compost • Lipinski Plumbing, Heating & Air Conditioning • Practical Applications & Maxville Truck & Repair
Quick Lane Tire & Auto Center • A Quiet Place • Slaby Electric, LLC • West Road Electric
The White Pig Tavern • Whitetail Bar & Grill

LincolnMarketing
SINCE 1984

This free publication is made possible by the advertisers and other local agencies and may not be reproduced. Please support the local advertisers in this publication. Comments and/or suggestions may be directed to: info@lincolnmarketing.us
View this publication online at: www.lincolnmarketing.us



Local Area Events

JANUARY

Bridal Expo | La Crosse
Gun Show | La Crosse
Midwest Farm Show | La Crosse
Winter Rec Fest | La Crosse

FEBRUARY

Ice Fishing Contest | Mondovi
Tuna Hotdish Smackdown | Stockholm

MARCH

Alma Fireman's Chili Feed
Spring Equinox Festival | Stockholm
Stockholm St. Patrick's Day Parade

APRIL

100 Mile Garage Sale | Throughout the Area
Lefse Time Anniversary Event | Fountain City
Easter Egg Hunt | Alma
Flood Run | Alma
Alma Ice Break
Village Wide Rummage Sale | Trempealeau

MAY

100 Mile Garage Sale | Throughout the Area
Great River Birding & Nature Festival | Alma
Broiler Days | Arcadia
Memorial Ride | Arcadia
Louella Blackdeer Fun Run | Black River Falls
Memorial Day Pow-Wow | Black River Falls
Kids with Cancer Event | Osseo
Fresh Art Spring Tour | Pepin
Blues Bash | Trempealeau
Hipbreaker Bike Tour | Trempealeau
Reggae Fest | Trempealeau

JUNE

Summer Festival | Alma
Strawberry Festival | Alma Center
Durand Funfest
Bass Tournament | Fountain City
Music in the Park | Pepin
Tour de Pepin | Pepin
Midsommer Swedish Festival | Stockholm
Catfish Days | Trempealeau

Local Area Events

JULY

Pepin County Junior Fair | Arkansaw
Festival in the Park | Black River Falls
Karner Blue Butterfly Festival | Black River Falls
NTPA Regional Tractor Pull | Ettrick
Trempealeau County Fair | Galesville
Mondovi Friendship Days
Stockholm Art Fair

AUGUST

Alma Rod & Gun Club Horse Pull
Blues on the Chippewa | Durand
Car Show and Cruise | Durand
Ettrick Fun Days
Lions Fall Festival | Fountain City
Polka Fest | Fountain City
Team Bass & Walleye Tournament | Fountain City
Buffalo County Fair | Mondovi

SEPTEMBER

Alma Music & Art Festival
Taste of Durand Fall Festival
Old Time Farm Fest | Fountain City
City-Wide Garage Sale | Galesville
Rocco's Memorial Gun Show | Onalaska
Lake Pepin Food, Wine & Cider Festival | Pepin
Laura Ingalls Wilder Days | Pepin
Village Wide Rummage Sale | Trempealeau

OCTOBER

Alma Area Museum Quilt Show
Haunted Halloween Walk | Alma
Apple Affair | Galesville
Apple Affair Bike Tour | Galesville
Fall Fresh Art Tour | Pepin
Fields of Terror | Pepin
Flyway Film Festival | Pepin

NOVEMBER

Tundra Swan Watch | Alma
Holiday Fair | La Crosse
Thanksgiving Day Community Dinner | La Crosse

DECEMBER

Holiday House Walk | Alma
Hometown Holiday with Santa | Alma
Durand Dazzle Day
Illuminated Parade | Durand
Stockholm Country Christmas

Rooms - Excellent Food and Cocktails

Alma Hotel, Bar & Restaurant

Lunch Specials All Day
Happy Hour 4pm-6pm Monday - Friday

Crystal Wieczorek
Owner

Located along the snowmobile trail in Alma
Phone 608-685-3380 • Alma, WI 54610

Residential Services

BUFFALO COUNTY

Aging & Disability	(608) 685-6324
Child Support	685-6322
Clerk Of Court	685-6212
Coroner	685-4433
Corporation Counsel	685-6236
County Clerk	685-6209
Court Administration	685-6234
District Attorney	685-6236
Emergency Management	685-6298
Extension	685-6256
Health & Human Services	685-4412
Highway	685-6226
Historical Society	685-6290
Land Conservation	685-6261
Land Information Services	685-6285
Maintenance	685-6220
Natural Resources	685-6224
Recycling	685-6298
Register of Deeds	685-6230
Register of Probate	685-6202
Sheriff	685-4433
Surveyor	685-6232
Treasurer	685-6215
Veterans Services	685-6219
Zoning	685-6218

Residential Services

TREMPEALEAU COUNTY

Aging & Disability	(715) 538-2001
Child Support	538-2311 Ext. 312
Circuit Court	538-2311 Ext. 5
Corporation Counsel	538-2311 Ext. 245
County Clerk	538-2311 Ext. 201
Emergency Management	538-2311 Ext. 215
Extension	538-2311 Ext. 208
Information Systems	538-2311 Ext. 334
District Attorney	538-2311 Ext. 279
Human Resources	538-2311 Ext. 224
Land Management	538-2311 Ext. 223
Land Records	538-2311 Ext. 343
Maintenance	538-2311 Ext. 282
Public Health	538-2311 Ext. 6
Register of Deeds	538-2311 Ext. 244
Senior Services	538-2311 Ext. 250
Sheriff	538-4509
Treasurer	538-2311 Ext. 219
Veterans Services	538-2311 Ext. 217

PEPIN COUNTY

Child Support	(715) 672-8941
Circuit Court	672-8861
County Clerk	672-8857
District Attorney	672-8939
Economic Development	672-5709
Extension Office	672-5214
Health Department	672-5961
Highway Office	672-8171
Human Services	672-8941
Land Conservation	672-8665
Natural Resources	672-8476
Recycling	672-8704
Register of Deeds	672-8856
Sheriff	672-5944
Treasurer	672-8677
Veterans Services	672-8887

Practical Applications & Maxville Truck & Repair

- Farm Truck Repair and Setup
- Large Truck Repair & Setup
- Hydraulic Repair

**Phone (715) 672-PUMP
(7867)**

Durand, WI 54736

Chris Lindstrom



Buffalo County History (Alma, County Seat)

The first settlement in Buffalo County was in Fountain City in 1839. Before white settlers arrived, the area was inhabited by Dakota and Sioux Indians. Many early settlers were attracted to the abundance of trees for timber. The lumber industry became very prosperous in the county and aided the arrival of railroads and steamboat traffic on the Mississippi River. With the decline of the lumber industry towards the end of the 1800s agriculture became very prominent and was the new largest industry in the county. Wheat was the main crop, making Buffalo County one of the largest exporters of wheat in Wisconsin. By 1900 Buffalo County had a population of 16,765 people. Today Buffalo County is home to approximately 13,425 residents.

CITIES:

ALMA – pop. 869

BUFFALO CITY – pop. 1,013

FOUNTAIN CITY – pop. 992

MONDOVI – pop. 2,561

VILLAGES:

COCHRANE – pop. 390

NELSON – pop. 372

TOWNS:

ALMA – pop. 389

BELVIDERE – pop. 442

BUFFALO – pop. 657

CANTON – pop. 316

CROSS – pop. 378

DOVER – pop. 534

GILMANTON – pop. 472

GLENCOE – pop. 492

LINCOLN – pop. 864

MAXVILLE – pop. 343

MILTON – pop. 518

MODENA – pop. 321

MONDOVI – pop. 453

MONTANA – pop. 314

NAPLES – pop. 591

NELSON – pop. 603

WAUMANDEE – pop. 525

**Populations are approximate.*

Buffalo County Communities

ALMA (COUNTY SEAT)

Alma was first settled in 1848 by two Swiss men who came to the area to cut wood which would be used as fuel for steamboats. They built a shack and decided to stay. The original name for the community was Twelve Mile Bluff, because of the steep river bluffs that the city was built under. The name was changed to Alma after the battle on the Alma River in 1854 that took place in Russia and the community was selected as the county seat. Railroads arrived in 1885 and brought larger populations as well as business and industry. Another large increase in the population came after the U.S. Lock and Dam #4 was built in 1935 and after the Dairyland Power Cooperative plant was established. Today Alma is home to approximately 869 residents.

BUFFALO CITY

Buffalo City was chartered in 1859, making it the oldest incorporated city in Buffalo County. At one time it was the smallest city in the United States. Buffalo City was named after the county as well as after three brothers who raised buffalo on top of the bluffs that overlooks the city. Today Buffalo City is home to approximately 1,013 residents.

FOUNTAIN CITY

Originally named Holmes Landing, Fountain City was the home of the first permanent settlement in Buffalo County in 1839. Holmes Landing was named in honor of a family of the first settlers who often traded with the Sioux and Chippewa Indian tribes. Original industries in the area included timber and farming. The community was incorporated as a city in 1889 and businesses, churches and schools were established. Its name was changed to Fountain City shortly after incorporation because it had many water streams that are found north of the city. Old Time Farm Fest takes place every labor day weekend in the town to celebrate the rich history of agriculture. Today Fountain City is home to approximately 992 residents.

MONDOVI

Mondovi was first settled in 1855 by Harvey P. Farrington, a businessman from the eastern United States. The first store was established shortly after in 1857. The populations increased with the arrival of the railroad to the community. The North Western Line Railroad laid its tracks through the town and established a station. The community was a prosperous railroad community and became an important shipping area for most of the county, this soon led to Mondovi becoming the largest town in the county after its incorporation in 1899. Agriculture also played an important role for the residents of Mondovi. Main crops included, oats barley and wheat. Today Mondovi is home to approximately 2,561 residents.



Trempealeau County History (Whitehall, County Seat)

Trempealeau County's name is derived from the French phrase "La Montagne Qui Trempe Dans L'Eau" which translates to "Mountain that is steeped in Water." The area received its name in 1731 and was based off of the mountain that is found near the village of Trempealeau that is surrounded by water. The first permanent settlers were fur traders who arrived in 1840s looking to establish new trading posts. Business and Industry early on revolved around fur trading. Eventually agriculture replaced the trading industry as the largest in the county. By 1900 Trempealeau County had a population of 23,114 people. Today Trempealeau County is home to approximately 27,754 residents.

CITIES:

BLAIR – pop. 1,246

OSSEO – pop. 1,629

VILLAGES:

ETTRICK – pop. 501

PIGEON FALLS – pop. 387

PRESTON – pop. 966

STRUM – pop. 1,024

TREMPEALEAU – pop. 1,518

TOWNS:

ALBION – pop. 670

ARCADIA – pop. 1,693

BURNSIDE – pop. 572

CALEDONIA – pop. 795

CHIMNEY ROCK – pop. 322

DODGE – pop. 439

ELEVA – pop. 637

ETTRICK – pop. 1,377

GALE – pop. 1,511

GALESVILLE – pop. 1,447

HALE – pop. 1,075

INDEPENDENCE – pop. 1,212

LINCOLN – pop. 864

PIGEON – pop. 953

SUMNER – pop. 846

TREMPEALEAU – pop. 1,627

UNITY – pop. 558

WHITEHALL – pop. 1,600

**Populations are approximate.*

Trempealeau County Communities

ARCADIA

Arcadia was founded in 1855 by four men from Dodge County who came looking to set up a new area for trade and business. The community was originally named Bishop's Settlement, after the town's founder. The town was renamed Arcadia after the area had reminded a settler of the mountainous region in Greece by the same name. Soon after it was settled the community was incorporated as a town in 1857 and the first school started later that year. The railroad was completed in the area in 1873 and with it brought in larger populations of people. One year later the town was officially platted on January 27, 1874. Today Arcadia is home to approximately 1,693 residents.

BLAIR

First known as Porterville, the community was established on the North Western Line Railroad. Blair was renamed in honor of John Insley Blair of New Jersey who donated \$1,000,000 to the U.S. Government during the Civil War. Blair was known as one of the best shipping towns for its size in the state. The community was incorporated in 1894 and businesses, churches and schools were established. Today Blair is home to approximately 1,246 residents.

DODGE

The community was named for William E. Dodge, a philanthropist and financier who spent many years in New York. The railroads arrived in 1873 bringing in a larger population base as well as new business. The community was established as a busy trading center with agriculture as the main industry. Dodge was later platted on February 24, 1874. Today Dodge is home to approximately 439 residents.

GALESVILLE

Galesville was named in honor of Judge George Gale. The community grew fast and was founded, settled and platted in 1854. Galesville was named the first county seat of Trempealeau soon after it was platted. The community lost the county seat in 1876 to Whitehall which took away some hotel and legal business. The railroad came through the area in 1883 bringing in larger populations and business continued to thrive. Today Galesville is home to approximately 1,447 residents.

Trempealeau County Communities

OSSEO

Osseo's name was derived from the Indian word "ossi" which translates to "stone". The name is also featured in the "Song of Hiawatha" and "Osseo the son of the evening star", two songs that were created by Native Americans. The first homes in Osseo were built in 1860, and all the timber for the buildings were made from jack pines native to the area. Early settlers were of Norwegian descent and brought with them a rich heritage to the area. A mill was established soon after settlement and offered jobs for members of the community. A village hall was later built in 1936. Soon after Osseo was incorporated as a city in 1941. The city's Norwegian heritage is still visible today with the celebrating of many Norwegian traditions and festivals. Today Osseo is home to approximately 1,629 residents.

WHITEHALL (COUNTY SEAT)

In 1855 the first pioneers, who were attracted to the ample natural resources, reached the Whitehall area. As rail lines were built in the 1870s, Whitehall was a major stop and the access to transportation appealed to the new settlers. The community was a major trading area in the county thanks to the new busy railroad. The area began to develop and by the 1880s Whitehall housed a mill, tobacco warehouse, a creamery, a pickling station, three elevators, two banks and a newspaper. Whitehall was later incorporated in 1887 and continued to grow. Today Whitehall is home to approximately 1,600 residents.



A Quiet Place

Therapeutic Massage • Deep Tissue
Neuromuscular • Trigger Point
Relaxation

N7654 - 690th Street • Menomonie

715.235.7182

*Advertisers
Appreciate It...*

**Tell Them You Saw
Their Ad In The Guide!**

LincolnMarketing
SINCE 1984

651.646.4683



Pepin County History (Durand, County Seat)

Pepin County was originally inhabited by Dakota Indians who lived in the area for thousands of years before the first European settlers came in the eighteenth and nineteenth century. Originally Pepin County was parts of both Chippewa and Dunn Counties but was later separated on February 25, 1858 when it was created by a special act of the Wisconsin Legislature. Many of the early settlers were attracted to the rich fertile soil that was used for agriculture. Pepin's proximity to the Mississippi River also was a major attraction that helped draw people to the area. Railroads and steamboat travel helped bring in larger populations to the area making Pepin County an industrial and commercial hub. By 1900 Pepin County had a population of 7,905 residents. Today Pepin County is home to approximately 7,293 residents.

CITIES:

DURAND – pop. 1,859

VILLAGES:

PEPIN – pop. 908

STOCKHOLM – pop. 95

TOWNS:

ALBANY – pop. 662

DURAND – pop. 689

FRANKFORT – pop. 386

LIMA – pop. 758

PEPIN – pop. 608

STOCKHOLM – pop. 82

WATERVILLE – pop. 878

WAUBEEK – pop. 432

**Populations are approximate.*

Pepin County Communities

DURAND (COUNTY SEAT)

Durand was first settled in 1856 when Miles Durand Prindle came up on the Chippewa River. Prindle platted the land and named the city after himself. Populations increased with the arrival of railroads to the area and schools, churches and businesses were established. The first post office was established in 1858 and the community was incorporated as a village in 1871. Eventually Durand was incorporated as a city on April 12, 1887. Durand became the largest wheat growing producer in the area, making it one of the more prosperous communities in the county. A boom in population increased when a steel bridge was constructed in 1902 that crossed the Chippewa River making travel easier for everyone in the community. Today Durand is home to approximately 1,859 residents.

PEPIN

Pepin was first settled in 1846 by two French brothers who were trappers named Pepin. The community was known as a steamboat boom town and was the summer home of wealthy Chicago socialites and famous author Mark Twain. Pepin is also credited as the hometown of Laura Ingalls Wilder, the author of "Little House in the Big Woods" and "Little House on the Prairie". The fishing industry was very prominent for the town. In the 1890s, Pepin would annually bring in \$125,000 to \$250,000 with most of the fish being sent to New York. Today Pepin is home to approximately 908 residents.

STOCKHOLM

Stockholm was first settled in 1852 by Eric Peterson, a farmer who came to the area because of the fertile land for agriculture. The post office was established years later in 1860. The community was incorporated in 1903 and as businesses established the community continued to grow. Today Stockholm is home to approximately 95 residents.

WHITETAIL BAR AND GRILL

***Fun Times --- Friendly Service
Homemade Pizzas --- Hall Rental***

11:00 A.M. - Closing
Urne, WI

715-673-4411



Local Area Attractions

ARCADIA COUNTRY CLUB

340 Golf Ln. | Arcadia | (608) 323-3626

BIG RIVER THEATER

121 S Main St. | Alma | (608) 685-4859

BRUSH TROPHY ROOM MUSEUM

W22660 Soby Ln. | Galesville | (608) 539-5030

CASTLE MUSEUM

402 S 2nd St. | Alma | (608) 685-4231

ROCK IN THE HOUSE

440 N Shore Dr. | Fountain City | (608) 687-6106

DURAND VISITOR THEATRE

110 E Main St. | Durand | (715) 672-3456

ETTRICK GOLF CLUB

22952 Fairway Ave. | Ettrick | (608) 525-6262

LAURA INGALLS WILDER MEMORIAL SOCIETY

312 3rd St. | Pepin | (715) 442-2142

MINNESOTA MARINE ART MUSEUM

800 Riverview Dr. | Winona | (507) 474-6626

OLD COURTHOUSE MUSEUM

315 W Madison St. | Durand | (715) 672-5653

PEPIN COUNTY HISTORICAL SOCIETY

315 W Madison St. | Durand | (715) 672-5423

PEPIN DEPOT MUSEUM

806 3rd St. | Pepin | (715) 442-6501

POLISH CULTURAL INSTITUTE

102 Liberty St. | Winona | (507) 454-3431

ROLLING GREENS GOLF COURSE

1324 W 3rd Ave. | Durand | (715) 672-8139

SAND CREEK BREWING COMPANY

320 Pierce St. | Black River Falls | (715) 284-7553

TREMPEALEAU MOUNTAIN GOLF CLUB

W24411 Fairway Dr. | Trempealeau | (608) 534-7417

VALLEY GOLF CLUB

580 Golf Rd. | Mondovi | (715) 926-4913

WALNUT GROVE GOLF COURSE

W1440 Cty. Rd. O | Cochrane | (608) 248-2800

WHITEHALL LANES

36423 Main St. | Whitehall | (715) 538-4941

WINGS OVER ALMA NATURE CENTER

118 N Main St. | Alma | (608) 685-3303

Parks & Recreation

HOLDEN PARK

Arkansaw | (715) 672-8665

Located in Durand, Holden Park features 18 campsites, rifle ranges, fishing opportunities, a swimming beach and picnic areas.

MERRICK STATE PARK

Fountain City | (608) 687-4936

Located 3 miles north of Fountain City, Merrick State Park offers over 2 miles of hiking trails and cross-country ski trails in the winter months. The park also features fishing, canoeing and camping opportunities as well as excellent wildlife viewing areas.

PERROT STATE PARK

Trempealeau | (608) 534-6409

Located in Trempealeau, Perrot State Park features 12.5 miles of hiking trails and 9 miles of cross-country ski trails. The park also offers kayak and canoe rentals, 102 campsites and a nature center.

PIETREK PARK

Arcadia | (715) 538-2311

Located on 100 acres four miles north of Arcadia, Pietrek Park features nature trails, picnic areas, a picnic shelter, campsites and restroom facilities.

TAMARACK CREEK BOG NATURAL AREA

Trempealeau | (608) 534-6409

Located in Perrot State Park in Trempealeau, Tamarack Creek Bog Natural Area features hiking and cross-country ski trails and hunting and fishing opportunities.

TIFFANY BOTTOMS WILDLIFE AREA

Nelson | (608) 685-6222

Located on 12,500 acres in Nelson, the Tiffany Bottoms Wildlife Area offers hiking trails and 14 public boat launches. It also offers hunting and fishing opportunities and picnic areas.

TREMPEALEAU NATIONAL WILDLIFE REFUGE

Centerville | (608) 539-2311

Located on 5,617 acres near Centerville, Trempealeau National Wildlife Refuge offers many opportunities to view wildlife. The refuge features hiking trails, bicycle trails, cross-country ski trails, fishing opportunities, and a public boat launch with parking facilities. Hunting is allowed in the refuge with a special permit. Only hand-powered craft and boats with electric motors can be used in the refuge.

UPPER MISSISSIPPI RIVER NATIONAL WILDLIFE & FISH REFUGE

Onalaska | (608) 783-8405

Located on the Mississippi River near Onalaska, the Upper Mississippi River National Wildlife & Fish Refuge features nature trails, fishing piers, boat launches and wildlife watching opportunities.

**Call the following phone numbers for more information on parks and recreation in the area.*

Buffalo County: (608) 685-6224

Trempealeau County: (715) 538-2311, ext. 223

Pepin County: (715) 672-8665



DNR License Centers

You can purchase hunting and fishing licenses, cross-country ski passes and snowmobile trail stickers through the Electronic License System. Online: dnr.wi.gov, Toll Free: 1 (888) 936-7463 or visit one of the ELS agents available throughout Buffalo, Trempealeau & Pepin Counties:

ALMA

BUFFALO COUNTY CLERK

407 S Second St. | Alma | (608) 685-6209

KWIK TRIP #802

603 N Main St. | Alma | (608) 685-3879

ARCADIA

ARCADIA SPORTS

1015 W Main St. | Arcadia | (608) 323-7111

HOWARDS HARDWARE HANK

379 S Dettloff Dr. | Arcadia | (608) 323-3939

TRUE VALUE FARM HOME & AUTO

1475 E Wilson Ave. | Arcadia | (608) 323-7744

BLAIR

EXPRESS MART

126 N Spring St. | Blair | (608) 989-2781

COCHRANE

GRAETTINGERS HARDWARE

103 Main St. | Cochrane | (608) 248-2426

WAUMANDEE COUNTRY STORE

52017 Cty. Rd. U | Cochrane | (608) 626-3111

DURAND

PEPIN COUNTY CLERK

740 W 7th Ave. | Durand | (715) 672-8857

RYANS SPORTSHOP

406 W Main St. | Durand | (715) 672-4867

STRUM CENEX CONVENIENCE STORE

514 E Main St. | Durand | (715) 672-8947

DNR License Centers

ETTRICK

ETTRICK EXPRESS MART

301 S Washington St. | Ettrick | (608) 525-2820

HILLBILLY FUN GRILL & SALOON

15793 W 1st St. | Ettrick | (608) 525-7171

FOUNTAIN CITY

KWIK TRIP #835

41 Southshore Dr. | Fountain City | (608) 687-8591

GALESVILLE

MIKES BAR & GRILL

19833 E Gale Ave. | Galesville | (608) 582-2517

THE PIG STOP

N17544 Main St. | Galesville | (608) 582-3300

MONDOVI

MONDOVI ACE HARDWARE

735 E Main St. | Mondovi | (715) 926-4289

MONDOVI HARDWARE CO.

109 S Eau Claire St. | Mondovi | (715) 926-4289

NELSON

HANDY MART

5110 Hwy. 25 S | Nelson | (715) 673-4344

OSSEO

DIRECT STORES

50712 Oak Grove Rd. | Osseo | (715) 597-2327

STOCKMAN FARM SUPPLY

12524 Frontage Rd. | Osseo | (715) 597-2805

PEPIN

RIVER ROAD BP

300 3rd St. | Pepin | (715) 442-3033

WHITEHALL

MILLER TOWN & COUNTRY

19040 Dewey St. | Whitehall | (715) 538-4616

TREMPEALEAU COUNTY CLERK

36245 Main St. | Whitehall | (608) 323-7744

WHITEHALL CENEX CONVENIENCE STORE

36537 Main St. | Whitehall | (715) 538-2203

West Road Electric

Sales • Service **24 Hour Emergency Service**
Installation Commercial • Residential

Including Irrigation & Corn Dryers • Industrial • Farm

608-343-9690



Jason Olson over 11 Years of Experience

Wisconsin Hunting Seasons

For general information on firearm safety training call:
1 (888) 936-7463

WHITE TAILED DEER*

(NON-CWD & NON-METRO UNITS)

Bow: 09/17/11 - 11/17/11

Gun: 11/19/11 - 11/27/11

Muzzleloader: 11/28/11 - 12/07/11

Youth Deer Hunt: 10/08/11 - 10/09/11

Statewide Antlerless Hunt: 12/08/11 - 12/11/11

BLACK BEAR*

Dogs ARE NOT Permitted: 09/07/11 - 10/11/11

Dogs ARE Permitted: 09/07/11 - 10/11/11

WILD TURKEY

Youth Turkey Hunt: 04/09/11 - 04/10/11

Spring: 04/13/11 - 04/17/11; 04/20/11 - 04/24/11;

04/27/11 - 05/01/11; 05/04/11 - 05/08/11;

05/11/11 - 05/15/11; 05/18/11 - 05/22/11

Fall: 09/17/11 - 11/17/11

RING-NECKED PHEASANT

10/15/11 - 12/31/11

RUFFED GROUSE*

Zone A: 09/17/11 - 01/31/12

Zone B: 10/15/11 - 12/08/11

SHARP-TAILED GROUSE

10/15/11 - 11/06/11

BOBWHITE QUAIL

10/15/11 - 12/07/11

HUNGARIAN PARTRIDGE*

10/15/11 - 12/31/11

CROW

01/18/11 - 03/20/11; 09/17/11 - 11/17/11

MOURNING DOVE

09/01/11 - 11/09/11

GRAY & FOX SQUIRRELS

09/18/10 - 01/31/11

COTTONTAIL RABBIT

Northern Zone: 09/17/11 - 02/29/12

Southern Zone: 10/15/11 - 01/31/12

BOBCAT

10/15/11 - 12/25/11; 12/26/11 - 01/31/12

RED & GRAY FOXES

10/15/11 - 02/15/12

COYOTE

Continuous

RACCOON

Resident: 10/15/11 - 02/15/12

Nonresident: 10/29/11 - 02/15/12

WOODCOCK

09/24/11 - 11/07/11

CANADA GOOSE

09/01/11 - 09/15/11

**Please contact your local DNR office for specific hunting and trapping zone regulations.*



Wisconsin Trapping Seasons

COYOTE

10/15/11 - 02/15/12

BEAVER

Zone A: 11/05/11 - 04/30/12

Zone B: 11/05/11 - 04/30/12

Zone C: 11/05/11 - 04/30/12

Zone D: 1 day after duck season closes - 03/15/12

FISHER

10/16/10 - 12/31/11

BOBCAT

10/15/11 - 12/25/11; 12/26/11 - 01/31/12

OTTER

Northern Zone: 11/05/11 - 04/30/12

Central Zone: 11/05/11 - 03/31/12

Southern Zone: 11/05/11 - 03/31/12

FOX (RED & GRAY)

10/15/11 - 02/15/12

MINK

Northern Zone: 10/15/11 - 02/29/12

Southern Zone: 10/29/11 - 02/29/12

Winnebago Zone: 10/29/11 - 03/15/12

Mississippi River: 1 day after duck season closes

MUSKRAT

Northern Zone: 10/15/11 - 02/29/12

Southern Zone: 10/29/11 - 02/29/12

Winnebago Zone: 10/29/11 - 03/15/12

Mississippi River: 1 day after duck season closes

RACCOON

Resident: 10/15/11 - 02/15/12

Nonresident: 10/29/11 - 02/15/12

Hunting Safety

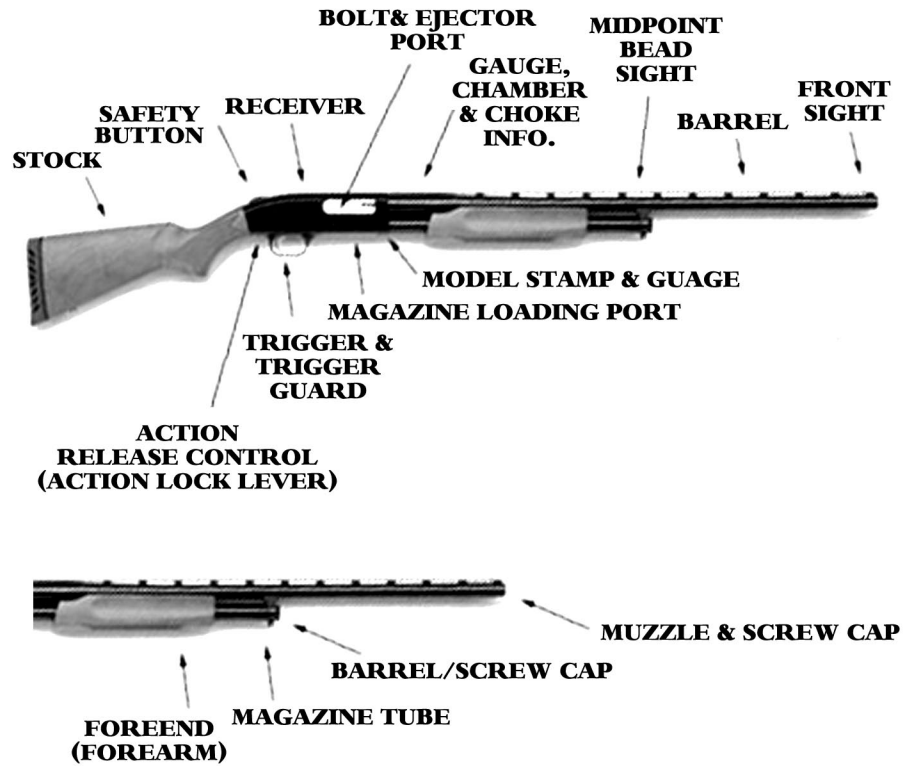

All hunters should consider taking an advanced hunter education class to learn the latest hunting techniques along with tips on coming home alive.

Here are five suggestions for a safe and successful hunting experience:

1. Get a detailed map of the area you are hunting, review it before you leave, and carry it with you in the field.
2. Carry a compass and know how to use it. Decide ahead of time the direction to head for if you get lost or disoriented.
3. Weather can change quickly in Minnesota, so hunters should carry a simple survival kit and be prepared for an unexpected overnight stay in the field. The survival kit should contain a rope, a knife, water, waterproof matches, an emergency shelter, and first aid supplies.
4. If you are on the water, make sure to wear a personal flotation device (life preserver).
5. Know your hunting partners' physical and emotional limitations, as well as your own, and don't push your partners or yourself beyond those limits.

Wisconsin Fishing Seasons

EARLY INLAND TROUT
03/05/11 - 05/01/11

GENERAL INLAND TROUT
05/07/11 - 09/30/11

LARGE & SMALLMOUTH BASS
Northern Zone (Catch & Release): 05/07/11 - 06/17/11
Northern Zone: (Harvest): 06/18/11 - 03/04/12
Southern Zone: (05/07/11 - 03/04/12)

MUSKELLUNGE
Northern Zone: 05/28/11 - 11/30/11
Southern Zone: 05/07/11 - 12/31/11

NORTHERN PIKE
05/07/11 - 03/04/12

WALLEYE
05/07/11 - 03/04/12

Lipinski Plumbing Heating & A/C

*Your Best Deal on Heating
& Cooling Systems*



**WHATEVER
IT TAKES**

Heating & Cooling Systems

Full stock on hand
furnaces and air
conditioners, water heaters,
softeners, faucets.

*Serving, Buffalo, Pepin,
LaCrosse, Jackson and
Trempealeau Counties.*

Septic and well installations
608-248-2475
WI MP #230927

OIL CHANGE SPECIAL

*Oil, lube, filter & multi-point
inspection &*

FREE
CAR WASH

CARS \$16.95  **TRUCKS \$19.95**

Up to 5 qts, 10W30, diesels extra.
Additional parts extra.

Special good thru December 31, 2011.
SOME RESTRICTIONS MAY APPLY

(715) 597-1946



Corners of I-94 & Hwy. 10, • Osseo

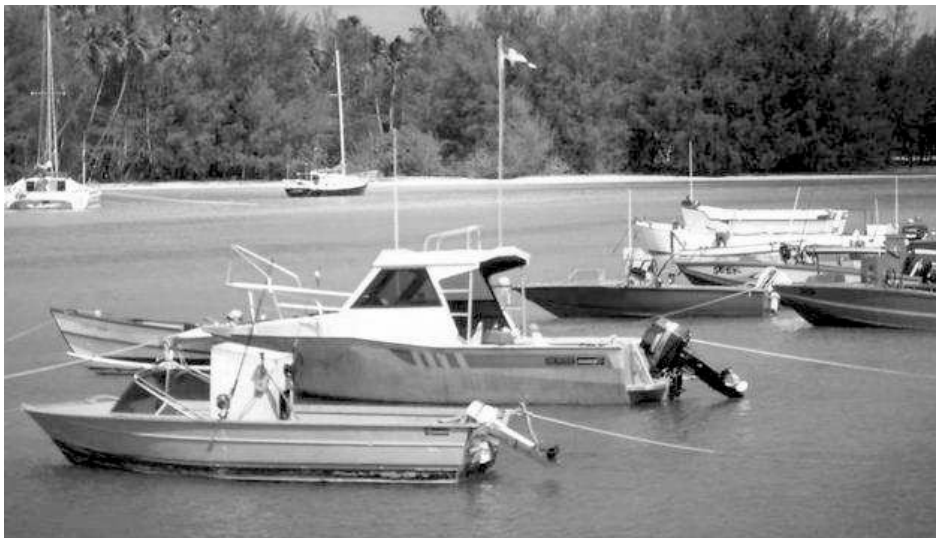

Boating Safety

Operating Watercraft

Follow these guidelines to help prevent and prepare for capsizing, swamping, or someone falling overboard.

- Make sure that you and your passengers are wearing life jackets while the boat is moving.
- Attach the ignition safety lanyard to your wrist, clothes, or life jacket.
- Don't allow anyone to sit on the gunwale, bow, seat backs, motor cover, or areas not designed for seating. Also, don't let anyone sit on pedestal seats when craft is not in idle.
- Don't overload your boat. Balance the load of passengers and gear stored on-board.
- Keep your center of gravity low by not allowing people to stand up or move around while craft is in motion.
- In small boats, don't allow anyone to lean beyond the gunwale.
- Turn boat at slow rates of speed.
- Secure the anchor line to the bow, never to the stern.
- Don't risk operating water craft in rough conditions or bad weather.

Boating Safety

Know Your Craft

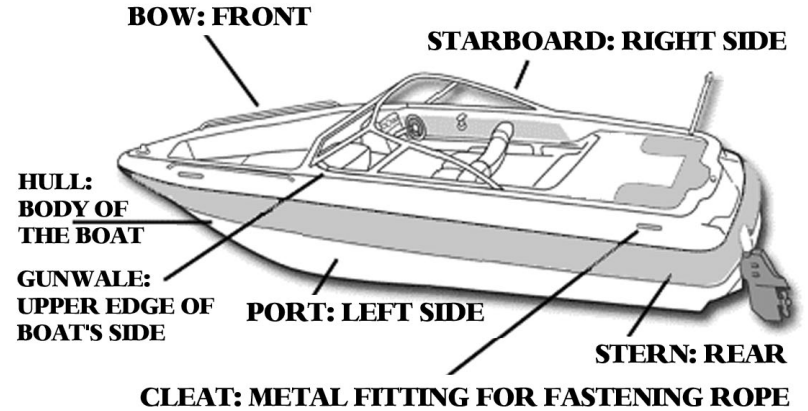

BEAM: MAXIMUM WIDTH OF BOAT

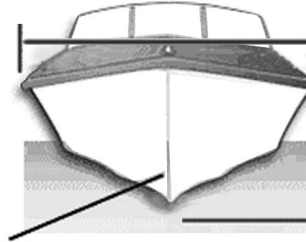

FREEBOARD: DISTANCE FROM WATER SURFACE TO LOWEST POINT WHERE WATER COULD COME ABOARD BOAT.

DRAFT: DEPTH OF WATER NEEDED TO FLOAT VESSEL

KEEL: CENTERLINE OF BOAT OR EXTENSION OF HULL (INCREASES STABILITY)

Who May Operate a Motorboat (Other Than a Personal Watercraft)

For engines 25 horsepower or less:

Those under age 12 may operate without restrictions.

For engines over 25 horsepower through 75 horsepower:

Those under age 12 must have someone 21 years of age or older on board within reach of the controls.

For engines over 75 horsepower:

No children under age 12 may operate, even with an adult on board.

Other restrictions apply to boat operators 12 to 17 years old:

Operators from 12 to 17 years of age may operate engines of 25 horsepower or lower with no restrictions.

For engines over 25 horsepower:

Operators 12 to 17 years of age must have:

A watercraft operator's permit, or someone age 21 years or older on board within reach of the controls.

Boating Safety

Flotation Devices



Offshore Life Jackets - Type 1:

For rough or remote waters where rescue may take awhile. Provide the most buoyancy, excellent for flotation, turns most unconscious persons face up in the water.



Near-Shore Vests - Type 2:

Good for calm waters when quick assistance or rescue is likely. Turns some unconscious wearers face up in the water, but not as efficiently as offshore life jackets.



Flotation Aids - Type 3:

Vests or full-sleeved jackets good for calm waters when quick assistance is likely. Not for rough waters. They will not turn most unconscious persons face up. Used for sports, such as water-skiing. Some inflate in water.



Unwearable / Throwable Devices - Type 4:

Cushions and ring buoys designed to be thrown to someone in trouble. Type 4 is not designed to be worn. Not for rough waters - not for anyone unable to hold on to it.



Special Use - Type 5:

Vests, hybrids/others designed for specific activities, for example windsurfing, kayaking, water-skiing. Some Type 5 devices inflate when entering the water. To be acceptable, Type 5 must be used in compliance with their label instructions.

All watercraft must have at least one Coast Guard Approved Type 1, 2, 3 or 5 flotation device that is the proper size for each person on board or being towed.

All devices must be in good condition and easily accessible.

Children under age 10 must wear a device when on board a boat that is underway unless: in an enclosed cabin or below deck or on an anchored boat that is being used for swimming or diving or passenger craft with a licensed captain.

Along with the above at least one approved Type 4 must be on board boats 16 ft. or longer (except canoes and kayaks) and immediately available.

A Coast Guard approved Type 5 device may be substituted for any other Coast Guard approved device if it meets the same requirements and is noted on the label.

Anyone riding a jet ski or other Personal Water Craft must wear an approved -non inflating flotation device, as well as anyone being towed by a water craft.

Bicycle Safety

- Always wear a properly fitting bike helmet as most serious injuries are to the head.
- Be sure your handlebars, seat and wheels fit snugly.
- Keep your bike in good shape by checking and oiling your chain, making sure your brakes work properly and maintaining your tire pressure.
- Always ride with both hands on the handlebars except when doing turn signals.
- When leaving a driveway, curb or alleyway always stop and check for traffic in both directions.
- Cross only at intersections.
- Use the crosswalk to walk your bike across busy intersections and follow the traffic signals.
- Never ride against traffic. Travel in the same direction as the cars.
- Whenever you can, use bike routes and avoid busy streets.
- Don't ride near parked cars as doors can open and cause accidents.
- Obey all traffic signs and traffic lights.
- When biking with friends, ride in a single file.
- Always pass other bikers or pedestrians on the left and say "On your left!" to make your presence known.
- Always use bicycle hand signals to alert traffic of your changing direction.

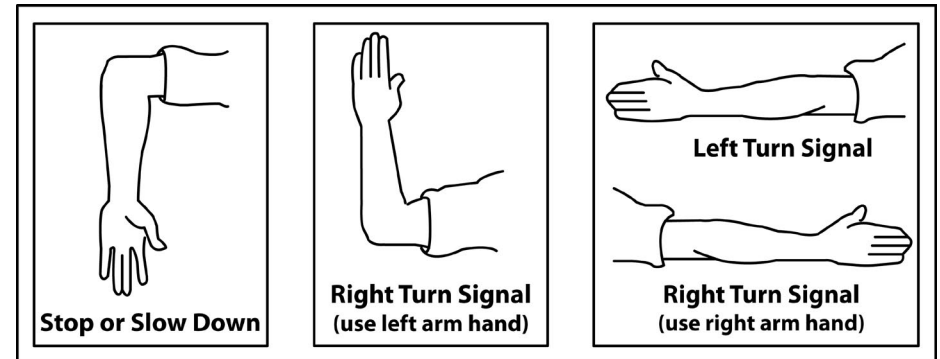

Bicycle Trails

BUFFALO COUNTY

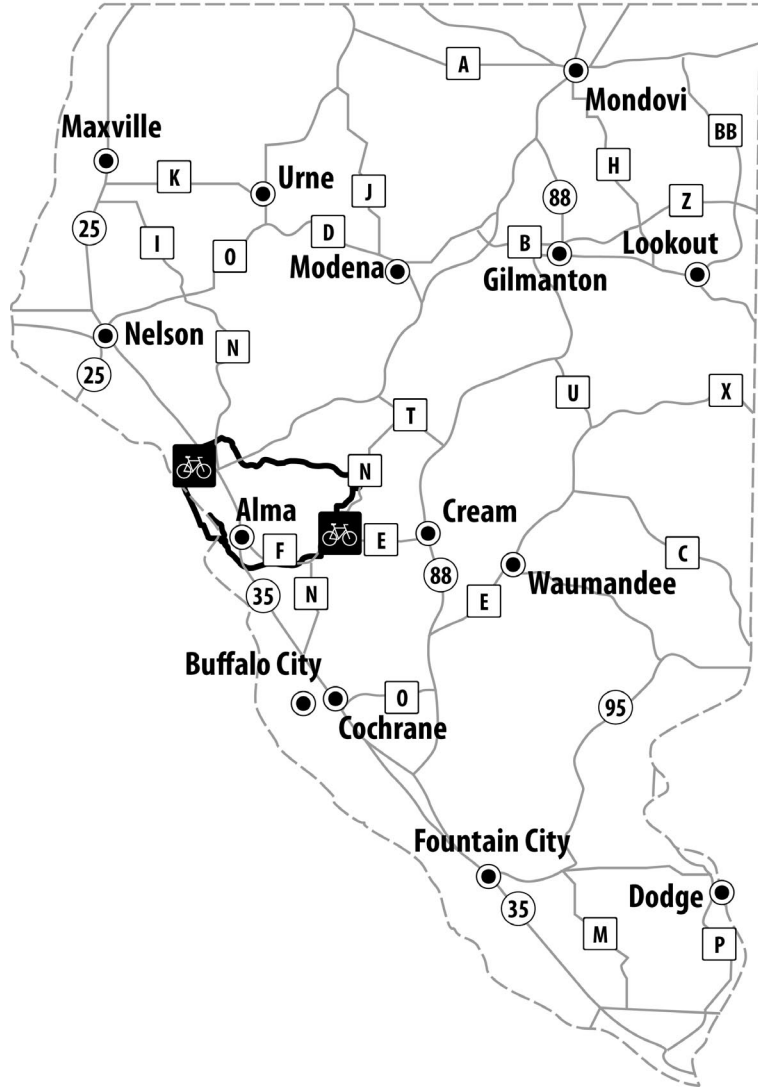

Bicycle Trails

TREMPEALEAU COUNTY

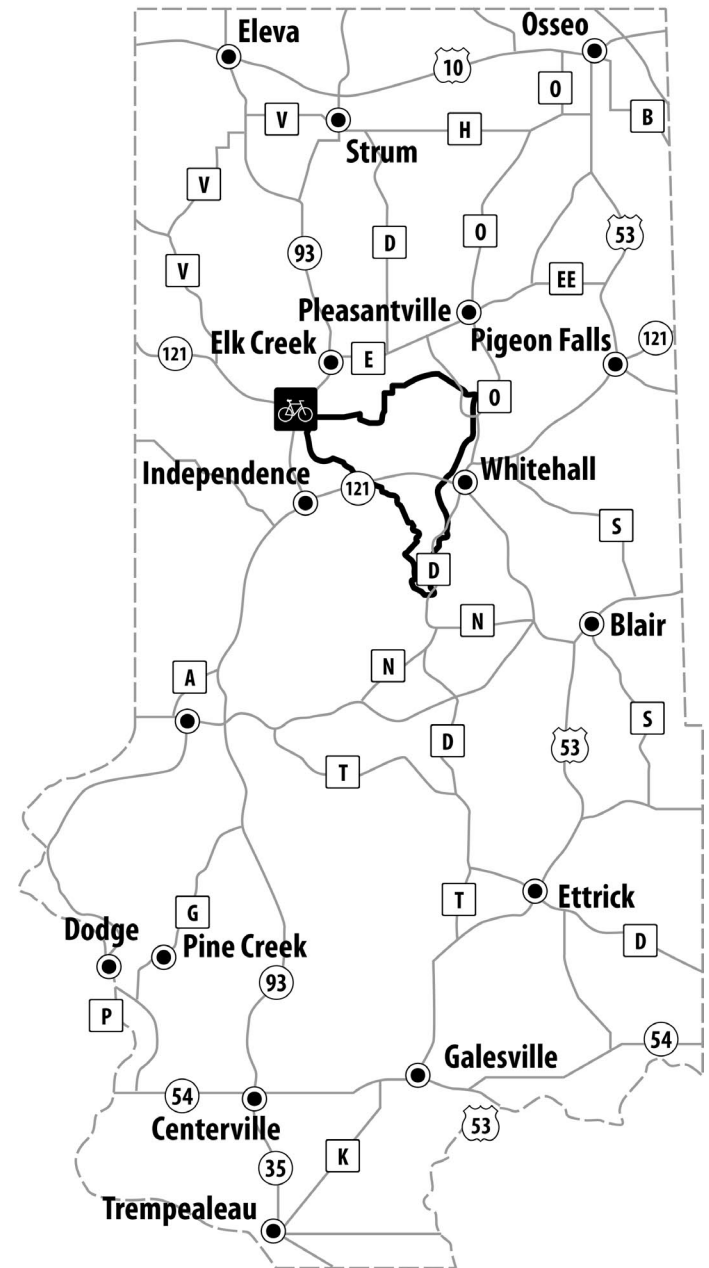

Bicycle Trails

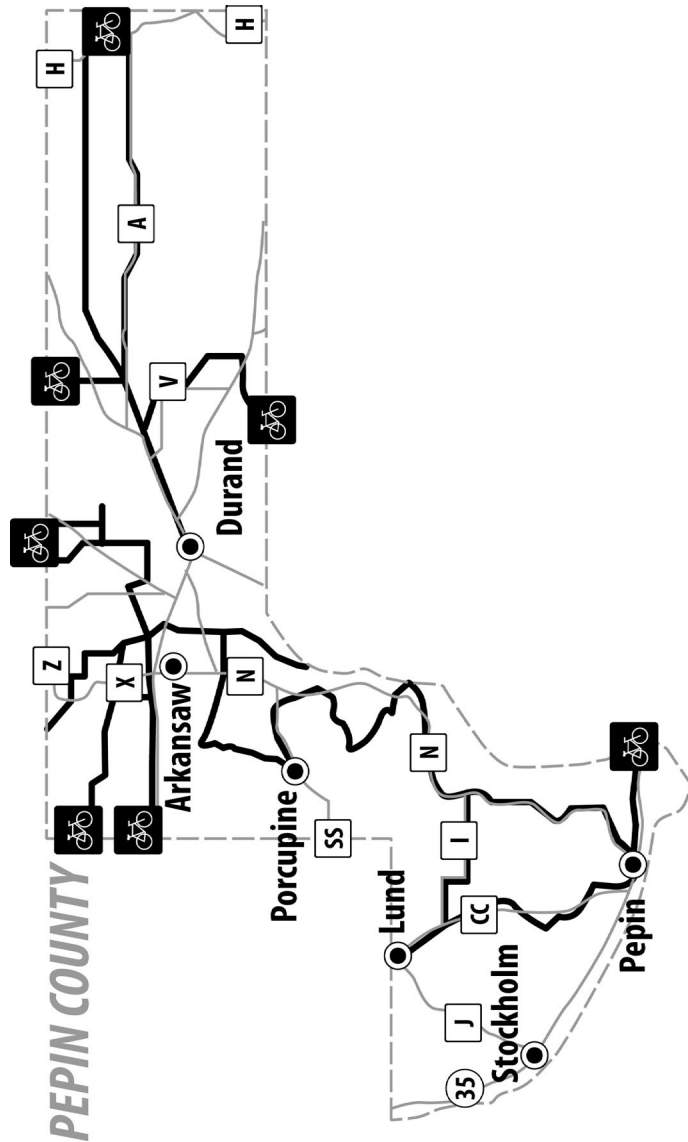

ATV Safety

- Read the owner's manual and know your vehicle thoroughly.
- Check your vehicle before you ride.
- Wear protective equipment and clothing.
- Don't lend your vehicle to unskilled riders.
- Supervise young or inexperienced riders.
- Never carry a passenger on vehicles meant for one rider.
- Do not operate under the influence of drugs or alcohol.
- Drive at speeds that are appropriate to trail conditions.
- Stay to the right on trails.
- Stay away from thin ice, open water and wetlands
- Know the weather forecast.
- Make sure headlights and taillights work properly.
- Maintain safe distances between other riders.
- Reduce your speed when riding at night.
- Yield to other motor vehicles and trail users.
- Young or beginning riders are encouraged to take a safety training course.



Snowmobile Safety

- Do not consume alcohol or take drugs prior to or during your snowmobile trip. Doing so increases your chances of injury or death.
- Slow down and don't cut to the inside of the trail corners. It's dangerous and illegal.
- If you snowmobile at night, don't override your lights.
- Always use the buddy system. Never ride off alone.
- Drowning is one of the causes of many snowmobile fatalities. Whenever possible, avoid the ice.
- Wear sensible, protective clothing designed for operating a snowmobile.
- Use a full size helmet, goggles, or visor to prevent injuries from twigs, stones, ice chips and other debris.
- Avoid wearing long scarves. They may get caught in moving parts of the snowmobile.
- Know the terrain you are going to ride. If unfamiliar to you, ask someone who has traveled over it before.
- Know the weather forecast, especially the ice and snow conditions.
- Be sure your snowmobile is in top-notch mechanical condition throughout the months of use.
- Familiarize yourself with the snowmobile you are driving. Thoroughly read the manual that accompanies the snowmobile.
- Do not pursue domestic or wild animals. That is not the conduct of a sportsman. Report such violations to the nearest law enforcement officer.

Common Trail Signs



Snowmobile Safety

Communication is an essential part of safe riding. Hand signals are a practical way to communicate between other riders and traffic.

Be sure to give easy to see and clear hand signals when snowmobiling. Hand signals should never be subtle, but always deliberate.

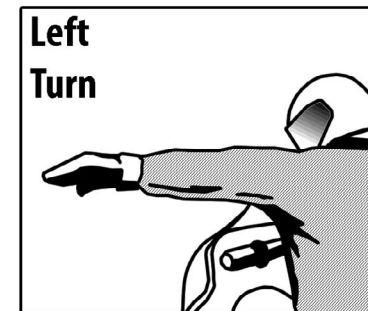
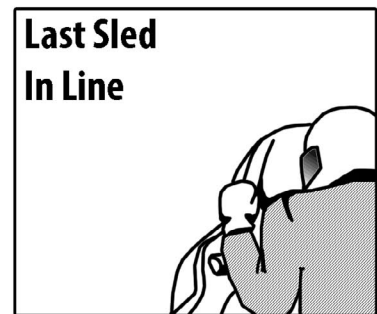
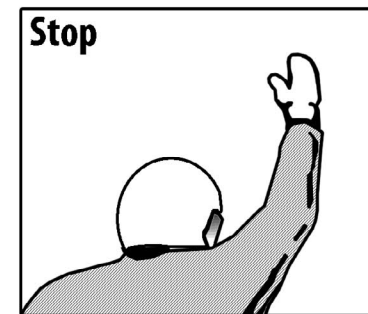
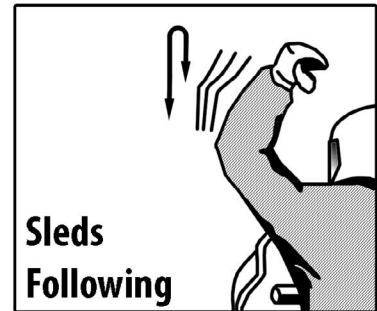
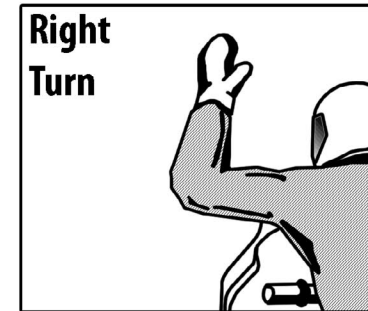
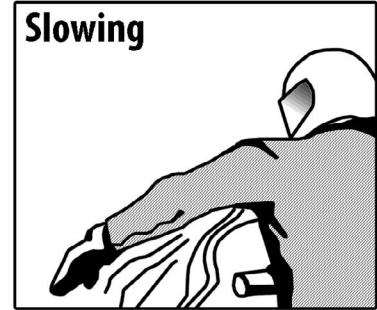

Snowmobile Trails

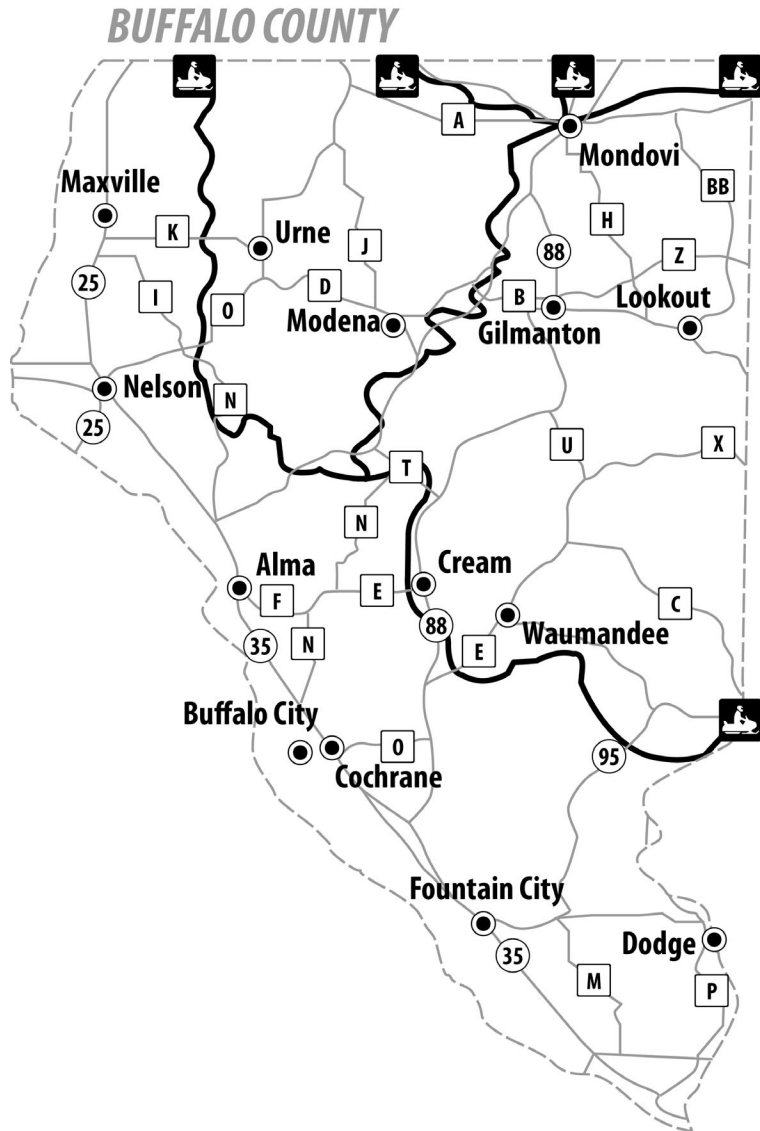

Snowmobile Trails

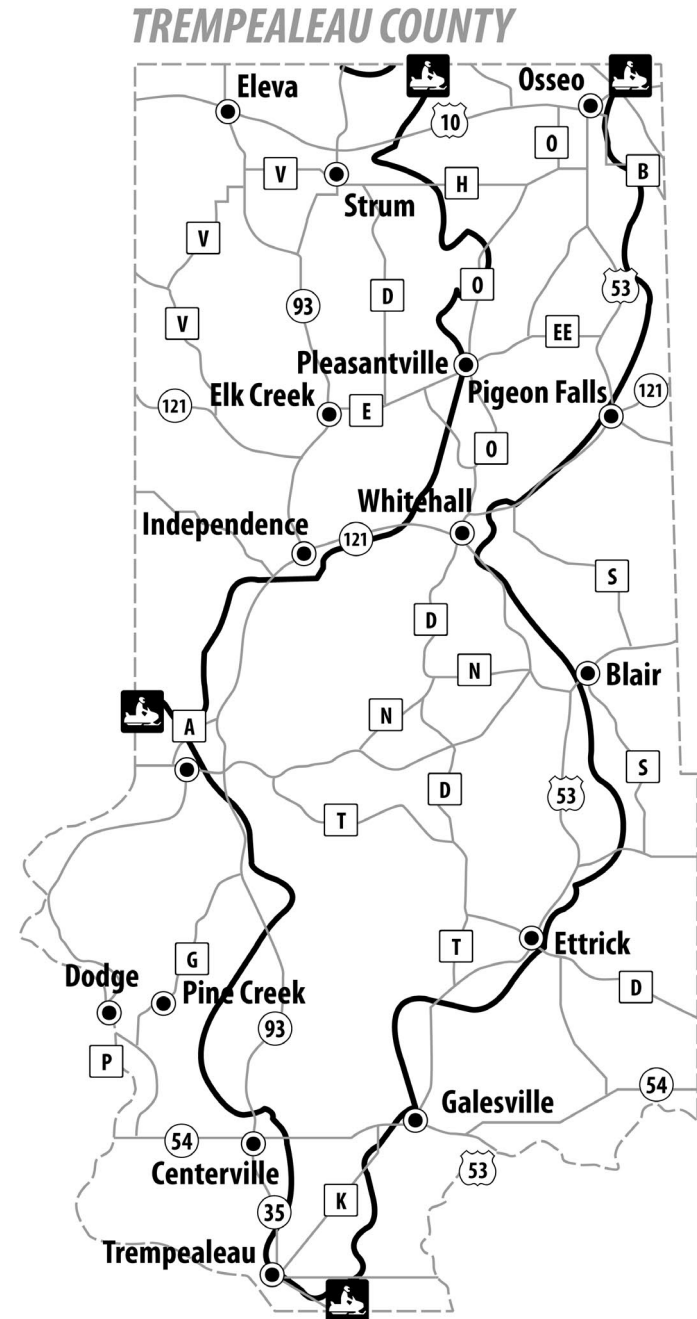

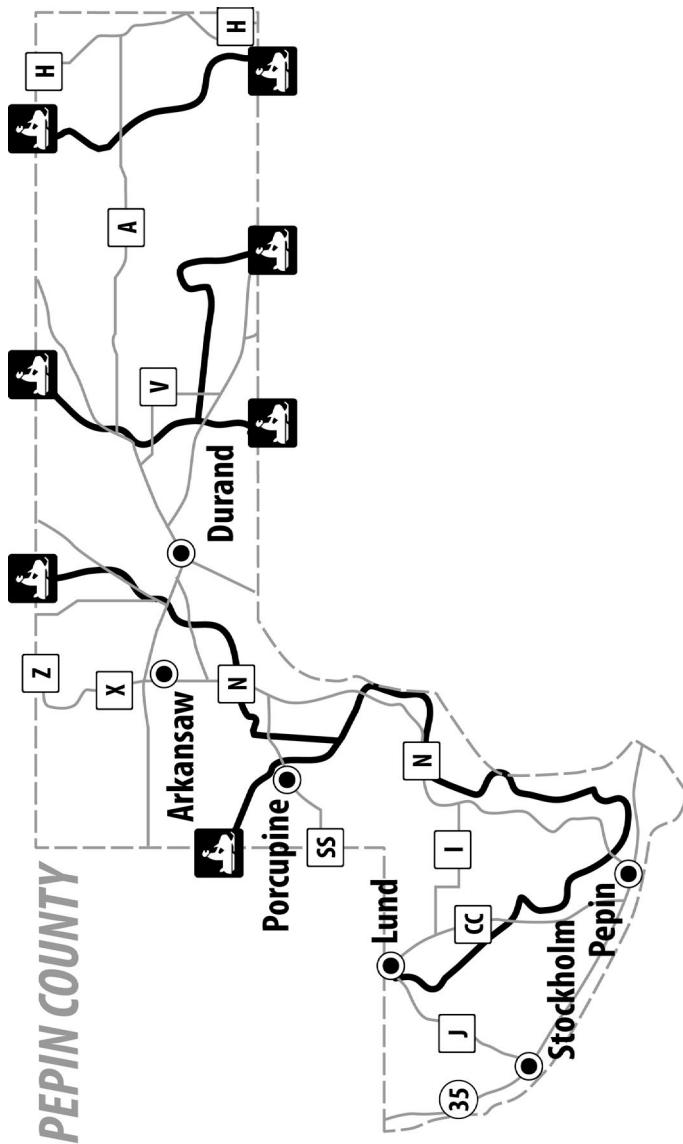

FIRST AID FOR CPR & HEART ATTACK

CPR

CPR is to be administered when a person is not breathing or has no pulse. Be quick to act by remembering the A,B,C's: Airway, Breathing & Circulation.

Airway:

Place the person on a firm surface, on their back. Kneel next to the person's neck and shoulders. Open the person's airway by tilting back the head and lifting the chin.

Breathing:

With the head tilted and chin lifted, pinch the nostrils shut and cover the person's mouth with yours. Give two slow breaths.

Circulation:

Find the hand position on the center of the breastbone. Place the heel of your hand on that position, with your other hand on top of the first hand. Use your upper body weight to push down. Give two compressions per second. Compress the chest at a rate equal to 100/minute. Perform 30 compressions at this rate. Repeat until an ambulance arrives.

HEART ATTACK

Symptoms of a heart attack may include any of the following:

- Uncomfortable pressure, fullness or squeezing pain in the center of the chest.
- Expanded pain in the upper abdomen.
- Shortness of breath.
- Pain or numbness in either arms, shoulders, neck, jaw or teeth.
- Dizziness or fainting.
- Nausea and sweating.

If you or someone else may be having a heart attack - follow these steps immediately:

- **DIAL 911**
- **Chew and swallow Aspirin (unless you are allergic/not allowed to)**
- **Take Nitroglycerin (only if prescribed)**
- **Begin CPR if the person is unconscious**

IN AN EMERGENCY, DIAL 911

⊕ *Emergency First-Aid Tips* ⊕

FIRST AID FOR BURNS & CHOKING

BURNS

For minor 1st and 2nd degree burns smaller than 3" in diameter: Cool the Burn. Run cool water over the burned area for 5 minutes, or until the pain diminishes. Never put ice on a burn!

Bandage the burn with sterile gauze:

It is important to use loosely wrapped gauze. This will avoid pressure and the bandage protects blisters. NEVER put lotions, vaseline, ointments or butter on burn. Do not break any blisters, which can cause infection.

Take Aspirin, Ibuprofen, Naproxen or Acetaminophen to relieve pain:

Minor burns usually heal with these basic treatments. Be aware for signs of infection which may include: increased pain, redness, fever, swelling or oozing. If symptoms develop, seek medical help. Avoid tanning the burned area for at least a year. Protect the area with sunscreen outdoors. Avoid giving aspirin to children.

For 3rd degree burns/all major burns - DIAL 911

DO NOT run cold water over large severe burns - this can cause shock.

DO NOT remove burnt clothing.

Check for signs of breathing/coughing/movement.

If there are no signs of breathing begin CPR.

Elevate burned areas above heart level, if possible.

Cover the burn(s) with cool, sterile, moist bandages, towels or cloth.

CHOKING

Most people clutch at their throats when choking, an obvious symbol for help. However, if a person isn't giving that signal, be alert for these indications. Inability to talk, difficulty breathing or noisy breathing, inability to cough forcefully, skin/lips/nails turning blue, loss of consciousness.

The Red Cross recommends a "five-and-five" method for first aid: First give five blows between the person's shoulders with the heel of your hand. Second, perform the Heimlich maneuver (abdominal thrusts) five times. Alternate between five back blows and five abdominal thrusts until the blockage is dislodged.

IN AN EMERGENCY, DIAL 911

⊕ *Emergency First-Aid Tips* ⊕

FIRST AID FOR INSECT BITES/ANAPHYLAXIS & POISON SAFETY

INSECT BITES/ANAPHYLAXIS

Anaphylaxis is a severe allergic reaction from insect bites (latex, food and drug allergies can also cause Anaphylaxis). Typical symptoms include hives, the swelling of lips or eyes, swollen throat, drop in blood pressure, light headedness, confusion, nausea or diarrhea. If someone is having an allergic reaction from an insect bite with these symptoms:

CALL 911.

Administer emergency prescription medication. See if the person is carrying special emergency allergy medicine and give it to them according to the directions.

Loosen tight clothing.

Lay the person down. The person should lay down on their back with feet elevated. Turn them on their side if they are vomiting or bleeding from their mouth to prevent them from choking.

If they are not breathing - administer CPR. Most insect bite reactions are mild and cause no allergic reaction. If stung by a bee, use a straight edged object, like a credit card, to scrape away the stinger. Don't use tweezers - they can pinch more venom out of the stinger. Apply an ice pack to the area and take an over the counter pain reliever.

POISON PREVENTION

Teach your children about poison and how it can look like a food or drink. They should always ask an adult before eating or drinking anything. Have them learn the poison control phone number: 1-800-222-1222 and keep it programmed or posted near all your phones. Here are some prevention tips.

Lock up your poisons and medications. Keep them out of the reach of children, lock them up if possible. Make sure your children understand that medicine is not candy.

Follow directions carefully. Read your labels. Be sure to use and store all poisons and medications properly according to recommendations.

Keep your pets safe from household chemicals, too. Don't allow pets near areas that have just been cleaned with chemicals, such as freshly mopped floors or bleached bathtubs and sinks. Clean up any antifreeze/coolant spills. Pets like the flavor but they can die if they ingest it. Store poisonous foods or plants in areas that your pets cannot access. Call your local emergency veterinary hospital if you believe your pet has been poisoned.

IN AN EMERGENCY, DIAL 911

Safety Tips for Parents & For Kids

PARENTS:

- Teach your kids that an emergency is when you need help from a doctor, a police officer or a firefighter.
- Designate a safe place by your house that a child can go to if they need help right away.
- Have your kids memorize your address and phone numbers. They should also know your full name and where you work.

KIDS:

FIRE SAFETY

- If you or someone else is on fire - remember to STOP, DROP and ROLL. Wrap a blanket on the person to help put out the fire.
- If there is a fire, leave the house as fast as you can! Crawl on the floor to avoid smoke and if the door is hot, don't open it - find another way out.
- Learn all the fire exits in your house. Assign a safe place outside for everyone to meet in case of a fire emergency.

HOME ALONE

- Never tell anyone that you are home alone.
- If someone calls and ask for your mom and dad, tell them "They cannot come to the phone right now, can you please call back later?"
- Do not answer the door, unless it is someone that you know your parents have okay'd them to come over.

Emergency Numbers For Kids

KEEP A COPY OF THIS LIST NEAR EACH PHONE IN YOUR HOUSE

MY ADDRESS: _____

MY PHONE NUMBER: _____

MOM AT WORK: _____

MOM CELL PHONE: _____

DAD AT WORK: _____

DAD CELL PHONE: _____

NEIGHBOR: _____

EMERGENCY CONTACT: _____

POISON CONTROL: 1-800-222-1222

EMERGENCY DIAL

911

2011

JANUARY

S	M	T	W	T	F	S
						1
2	3	4	5	6	7	8
9	10	11	12	13	14	15
16	17	18	19	20	21	22
23	24	25	26	27	28	29
30	31					

FEBRUARY

S	M	T	W	T	F	S
		1	2	3	4	5
6	7	8	9	10	11	12
13	14	15	16	17	18	19
20	21	22	23	24	25	26
27	28					

MARCH

S	M	T	W	T	F	S
		1	2	3	4	5
6	7	8	9	10	11	12
13	14	15	16	17	18	19
20	21	22	23	24	25	26
27	28	29	30	31		

APRIL

S	M	T	W	T	F	S
					1	2
3	4	5	6	7	8	9
10	11	12	13	14	15	16
17	18	19	20	21	22	23
24	25	26	27	28	29	30

MAY

S	M	T	W	T	F	S
1	2	3	4	5	6	7
8	9	10	11	12	13	14
15	16	17	18	19	20	21
22	23	24	25	26	27	28
29	30	31				

JUNE

S	M	T	W	T	F	S
			1	2	3	4
5	6	7	8	9	10	11
12	13	14	15	16	17	18
19	20	21	22	23	24	25
26	27	28	29	30		

JULY

S	M	T	W	T	F	S
					1	2
3	4	5	6	7	8	9
10	11	12	13	14	15	16
17	18	19	20	21	22	23
24	25	26	27	28	29	30
31						

AUGUST

S	M	T	W	T	F	S
	1	2	3	4	5	6
7	8	9	10	11	12	13
14	15	16	17	18	19	20
21	22	23	24	25	26	27
28	29	30	31			

SEPTEMBER

S	M	T	W	T	F	S
					1	2
3	4	5	6	7	8	9
10	11	12	13	14	15	16
17	18	19	20	21	22	23
24	25	26	27	28	29	30

OCTOBER

S	M	T	W	T	F	S
						1
2	3	4	5	6	7	8
9	10	11	12	13	14	15
16	17	18	19	20	21	22
23	24	25	26	27	28	29
30	31					

NOVEMBER

S	M	T	W	T	F	S
		1	2	3	4	5
6	7	8	9	10	11	12
13	14	15	16	17	18	19
20	21	22	23	24	25	26
27	28	29	30			

DECEMBER

S	M	T	W	T	F	S
					1	2
3	4	5	6	7	8	9
10	11	12	13	14	15	16
17	18	19	20	21	22	23
24	25	26	27	28	29	30
31						



"Great Homemade Food"

OPEN 5AM EVERYDAY

ATM and Major Credit Cards

Two Decks Overlooking Chippewa River

Three 52" TV's • DNR Registration Station

Canoe & Kayak Rental • Handicap Accessible

715-672-8874

318 West Main • Durand, WI

www.corralbarandriversidegrill.com



**Slaby
Electric
LLC**

**Electrical - Heating
Air Conditioning**

608-323-3241

Arcadia, Wisconsin

Asher Realty Group



Building our Community... One Family at a Time!



MARGE NICOLAI

GRI, ASP, CRS

715-797-6971

website: www.asherrealtygroup.com

email: marge@asherrealtygroup.com

